

QuietPower® QPO Series

Active Output Ripple Attenuators



10 and 20 Amp

Description

The QPO output ripple attenuator products use proprietary active filtering to reduce power supply output ripple and noise (PARD) over 30dB from 1kHz to 500kHz. QPOs improve transient response, ensures quiet point-of-load regulation and works with most DC-DC converters and switching-power supplies. Output regulation is maintained using remote sensing or the trim input of the power supply.

Load capacitance using this active technique can effectively be reduced by a factor of ten, providing equivalent transient performance. In the typical application schematic below the QPO was inserted between the converter and the load using no additional load capacitance. As shown in the performance plot, the drop in load voltage (approx. 10mV; channel 2) was significantly reduced when compared to the converter output (approx. 100mV; channel 1) with a 10A transient load current step. The ripple voltage amplitude was also reduced by a similar factor at the load.



Part Numbering

Part Number	Input Voltage	Current Rating	Attenuation	Package
QPO-1LZ-(01)	3 – 30V _{DC}	10A	>30dB PARD, 1kHz to 500kHz	25 x 25 x 4.5mm
QPO-2LZ-(01)	0.3 – 5.5V _{DC}	20A	>20dB PARD, 1kHz to 500kHz, Aux. Bus bias	

(-01 designates open frame)

Typical Application

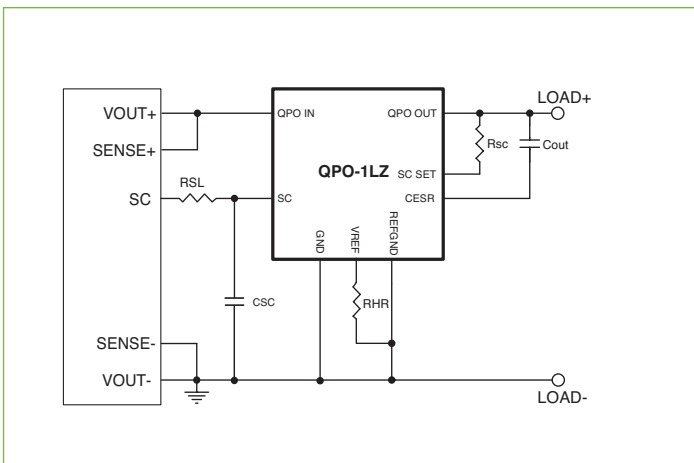

Figure 1 — Typical Application

Features & Benefits

- >30dB PARD attenuation, 1kHz to 500kHz
- Supports precise point-of-load regulation
- Up to 99% efficient
- High density, low profile LGA package
- Reduces required number of output capacitors to support dynamic loads
- User selectable optimization of attenuation, power dissipation, and transient load response
- Compatible with most DC-DC converters

Applications

- Telecom base station power amplifiers
- Low noise PoL
- Industrial test and measurement
- Sensors requiring low-noise power
- Medical instrumentation
- Military targeting and displays
- Lasers and optical systems

Performance

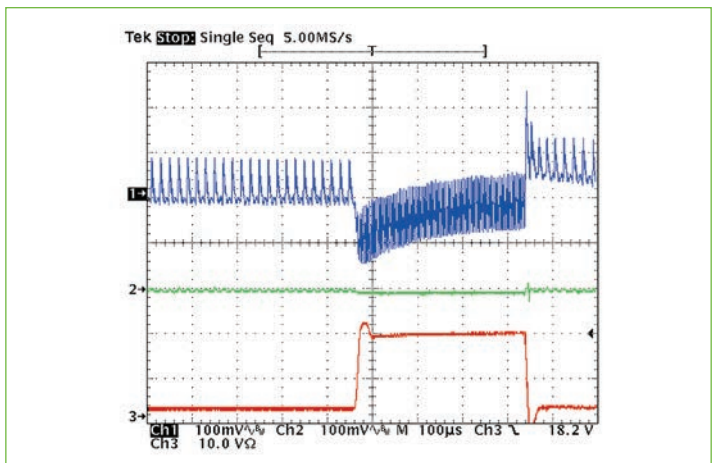

Figure 2 — Performance